

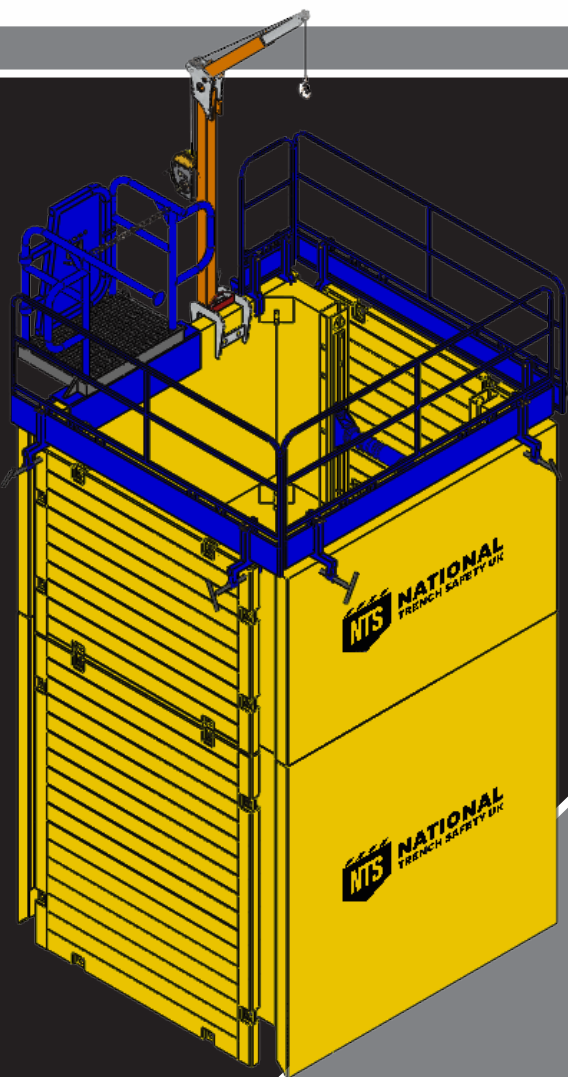

////
NATIONAL TRENCH SAFETY UK

MANHOLE BOX SERIES 600 USER GUIDE



MANHOLE BOX SERIES 600 USER GUIDE

Health & Safety



- **Improper assembly, installation and/or removal may cause serious injury or death.**
- **Ensure that the NTS Manhole Box Series 600 is used in accordance with this user guide.**
- **This User Guide is to be read & understood prior to assembly, installation.**
- **Ensure all persons engaged with the assembly, installation & removal of the system are suitably qualified.**
- **DO NOT allow a void between the panel and the ground.**
- **NEVER allow anyone inside the excavation during installation or removal.**
- **Non-compliance with this user guide may cause serious injury or death.**

Prior to any use, this user guide must be read carefully and understood by all those involved with the assembly, handling, installation, and removal of the excavation support system. This installation guide is to be followed during all stages of assembly, installation & removal.

NTS UK are not liable for the use of the trench support system in any way other than that described in this user guide, use in any other way may cause serious injury or death.

Any use of the excavation support system not detailed in this user guide must be highlighted by a specific design & site-specific instructions by NTS UK, use of the system outside the scope of this guide without the above is not valid.

PERSONAL PROTECTION EQUIPMENT (PPE)	
	WEAR SUITABLE PROTECTIVE GLOVES
	WEAR SUITABLE HEAD PROTECTION
	WEAR SUITABLE PROTECTIVE FOOTWEAR
	USE SUITABLE EYE PROTECTION
	USE SUITABLE HEARING PROTECTION

HAZARDS	
	GENERAL CAUTION/WARNING (E.G. DEEP EXCAVATION)
	RISK OF CRUSHED HANDS

REV 3.0: JUNE 2024

NTS (UK), UNIT 28 MOOR LANE TRADING ESTATE, MOXON WAY, LEEDS, LS25 6ES. 03332 076 007

The information contained within this guide remains the property of NTS (UK) and is not to be altered or reproduced without written permission. NTS (UK) reserves the right to change any data without giving prior notice. Once printed - uncontrolled.

Table of Contents

1.	General Guidance Notes.....	4
1.1.	Lifting & Transportation	4
1.2.	Measures to reduce hazards.....	4
1.3.	Personnel	5
1.4.	Maintenance and repair.....	5
1.5.	Small Plant, Tools, and Lifting Chains	5
1.6.	Access & Egress and Edge Protection	5
1.7.	During Installation Works	5
1.8.	After Installation Works.....	5
1.9.	Return of Equipment Off-Hire	5
1.10.	Transportation.....	6
1.11.	Stacking Arrangement.....	6
1.12.	Site Storage	6
2.	System Drawing	7
3.	Technical Parameters	8
3.1	Manhole Box Series 600	8
3.2	Allowable Earth Pressures	8
3.3	Spindle type 031/085 blue	9
3.4	Accessories	9
4.	Assembly Instructions	10
4.1	Manhole Box Series 600 Box Assembly	10
5.	Installation Instructions	11
5.1	Installation of Base Boxes	11
5.2	Installation of Top Boxes	13
5.3	Isometric Drawing	14
5.4	End Closure Panels	15
5.5	Before Entering the Trench.....	16
5.6	Entering the Supported Trench.....	16
5.7	Extraction of Manhole Box Series 600 Boxes	17
5.8	Precautions During Use and Maintenance	17

1. General Guidance Notes

The shoring must be uninterrupted and be in contact with the ground. Ensure observance of the permissible max. stress limits. Individual shoring units may only be used if the front sides are secured appropriately.

The following sets of rules and regulations in their current versions are to be observed:

- **Regulations of the BG Technical Committee for Civil Engineering**
- **DIN 4124 Excavations and Trenches**
- **DIN EN 13331 Part 1 & 2 Trench Lining Systems**
- **Rules for Occupational Health and Safety**
- **Accident prevention regulations / Occupational health and safety regulations**

Follow the instructions in this manual during installation.

This guide is to be used as a supplementary document to the Contractor's RAMS. All site operations are the responsibility of the Contractor, and this guide is intended as guidance for use with the Manhole Box Series 600 System ONLY and should be used in conjunction with any/all design documentation & drawings provided by NTS UK and any site assistance NTS UK have provided.

1.1. Lifting & Transportation

The shoring unit is to be slung only by means of the dedicated lifting rings & openings or accessories.

- **Lifting equipment must be suitable for the weight to be transported.**
- **For safety reasons, you must only use load hooks equipped with hook locks.**
- **Ensure the observation of the permissible traction limits.**
- **Transportation is to be carried out close to the ground and unnecessary swinging motions are to be avoided.**
- **Standing in the swivel range of the lifting device or under suspended loads is prohibited.**
- **Look out for overhead wires.**
- **The machine operator and banksman must maintain eye contact.**

ALL LIFTING, HANDLING & TRANSPORTATION OPERATIONS FALL UNDER THE RESPONSIBILITY OF THE CONTRACTOR & THEIR RAMS. THE ABOVE POINTS ARE TO AID THE USER IN THE SAFE LIFTING & TRANSPORTATION OF THE SYSTEM. ALL LIFTING TRANSPORTATION OPERATIONS ARE THE RESPONSIBILITY OF THE CONTRACTOR.

1.2. Measures to reduce hazards

- **The construction site must be adequately secured and signposted.**
- **Personnel must wear protective work clothing (helmet / safety shoes / gloves).**
- **Possible instabilities as a result of wind load must be taken into consideration during assembly or installation.**
- **Set the shoring units flat on a solid surface.**
- **In the case of sloping, pay special attention to stable storage of pre-assembled building components.**

1.3. Personnel

The Management of Health and Safety at Work Regulations require that personnel deployed are suitably trained, experienced, and supervised by a competent person. All lifting operations are to be controlled by an appointed person.

The main activities associated with Manhole Box use are:

- **Unloading and loading the delivery vehicle.**
- **Bolting up and pinning components together.**
- **Slinging and lifting the Manhole Box into position.**

1.4. Maintenance and Repair

- **Shoring units should always be checked for functionality before use.**
- **Keep all nuts and bolts tight and ensure all pins are correctly fitted with 'R' Clips, where required.**
- **Defective or deformed units must not be used.**
- **All repair to undertaken by NTS UK using original replacement parts.**

1.5. Small Plant, Tools, and Lifting Chains

Lifting chains of suitable lifting capacity, hook size, leg length and current certification should be used. A small lump hammer may be required to tap pins and 'R' clips into position.

1.6. Access & Egress and Edge Protection

Install the edge protection as soon as possible before entry into the excavation. A competent person should inspect the means of access and egress regularly.

1.7. During Installation Works

Lifting chains of suitable lifting capacity, hook size, leg length and current certification should be used. A small lump hammer may be required to tap pins and 'R' clips into position.

1.8. After Installation Works

Each excavation and Manhole Box Series 600 must be inspected daily before personnel begin work.

1.9. Return of Equipment Off-Hire

Clients should ensure that on removal, the equipment is returned clean and assembled as supplied.

1.10. Transportation

Ensure all equipment is loaded to the satisfaction of the vehicle driver and is securely restrained to the vehicle bed.

(Min. 3 straps per stack is recommended).

1.11. Stacking Arrangement

In dismantled form, panels should be stacked as shown with suitable timber dunnage. (Max. 4 panels per stack).

Ensure panels are stacked directly above one another and all panels in a stack are in the same orientation.

Do NOT stagger or offset the panels within a stack. Long struts should be stored on suitable timber dunnage. Small components should be stored in skips / bins.

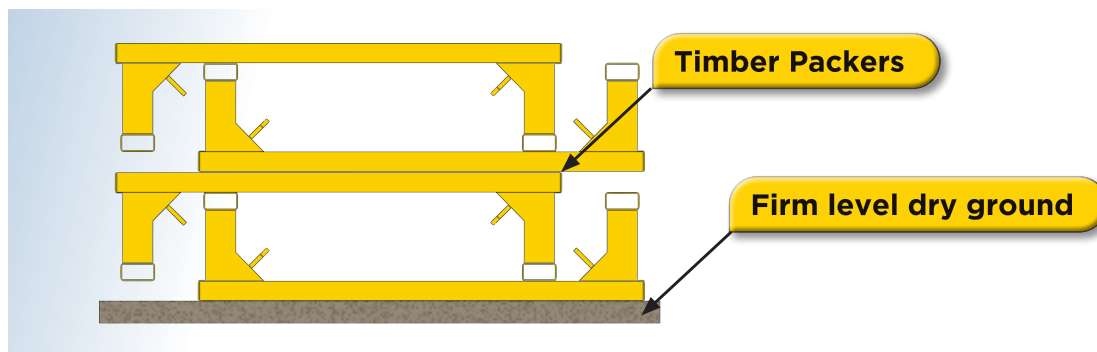

1.12. Site Storage

If not in use, separate base boxes from extension boxes. Dismantle extension boxes and store as above (8.1). Base boxes should be stored on their side or temporarily dug in when not in use (see below). Uneven or sloping ground and/or wind loading can result in inadequate stability if left upright.

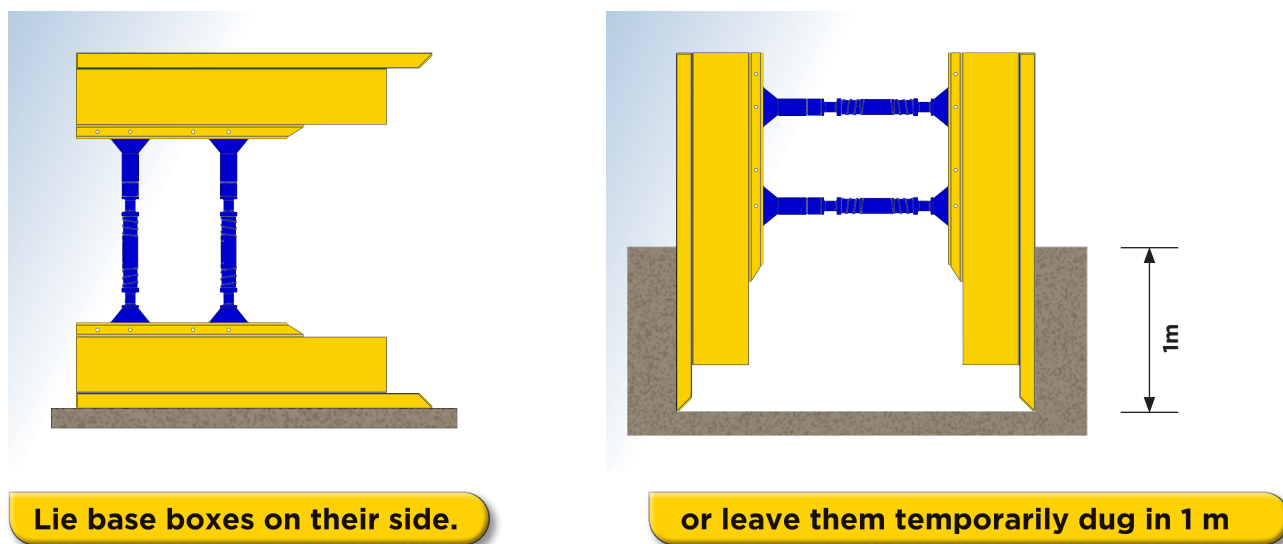

2. System Drawing

- H plate height
- t_{pl} plate thickness
- h_c spindle clearance height
- L plate length
- L_c spindle clearance length

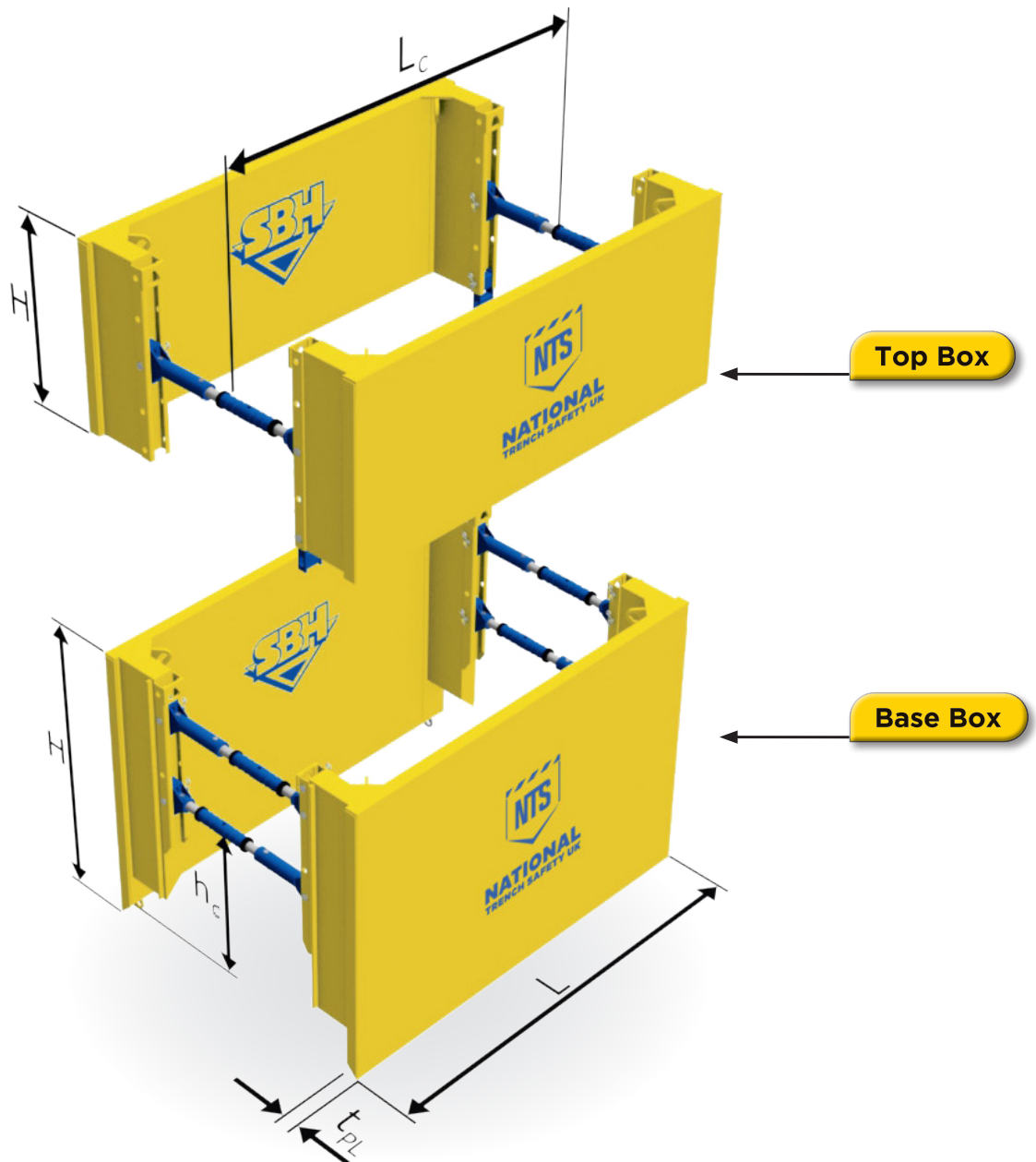

3. Technical Parameters

3.1 Manhole Box Series 600

The Manhole Box is always used when wider manholes have to be installed within a working trench. The trench shoring plate body is designed as a U-form and the wings have a thickness of 0,40 m. Thus, a 0,80 m wide manhole is formed. Ahead and behind the manhole, normal trench shoring boxes ensure the trench safety. The spindles and accessories are identical to those of the trench shoring boxes.

3.2 Allowable Earth Pressures

The Manhole Box is suitable for earth pressures up to 50 kN/m². Users should check that excavations do not impose loads greater than this.

Note: struts can not take sideways loading.

PLATE THICKNESS = 107 MM ALLOWED PLATE MOMENT = 79.1 KNM/M. ALLOWED SIDE PART MOMENT = 149 KNM

PANEL LENGTH - L (m)	PANEL HEIGHT - H (m)	PIPE CLEARANCE L _c (m)	PIPE CLEARANCE H _c (m)	MAX. PERM. EARTH PRESSURE (kN/m ²)	WEIGHT PER BOX (kg)
2.5	2.5	2.1	1.69	50.1	2350
	1.5				1620
3	2.5	2.6	1.69	41.8	2590
	1.5				1780
3.5	2.5	3.1	1.69	35.8	2825
	1.5				1940
4	2.5	3.6	1.69	31.3	3060
	1.5				2095
4.5	2.5	4.1	1.69	27.9	3596
	1.5				2388

SPINDLE TYPE 031/085 (BLUE) ALLOWED MOMENT = 1.7 KNM. ALLOWED TENSILE FORCES = 218 KN.

NUMBER OF EXTENSION PIPES 0.5m each	SPINDLE LENGTH (m)	WORKING WIDTH BETWEEN PLATES (m)	TRENCH WIDTH (m)	ALLOWED COMPRESSIVE FORCE (kN)	TOTAL WEIGHT (kg)
0	0.98 - 1.26	1.78 - 2.06	2 - 2.28	468	x
1	1.48 - 1.76	2.28 - 2.56	2.5 - 2.78	403	65
2	1.98 - 2.26	2.78 - 3.06	3 - 3.28	348	85
3	2.48 - 2.76	3.28 - 3.56	3.5 - 3.78	299	1.5
4	2.98 - 3.26	3.78 - 4.06	4 - 4.28	254	125
5	3.48 - 3.76	4.28 - 4.56	4.5 - 4.78	210	145
6	3.94 - 4.26	4.78 - 5.06	5 - 5.28	165	184

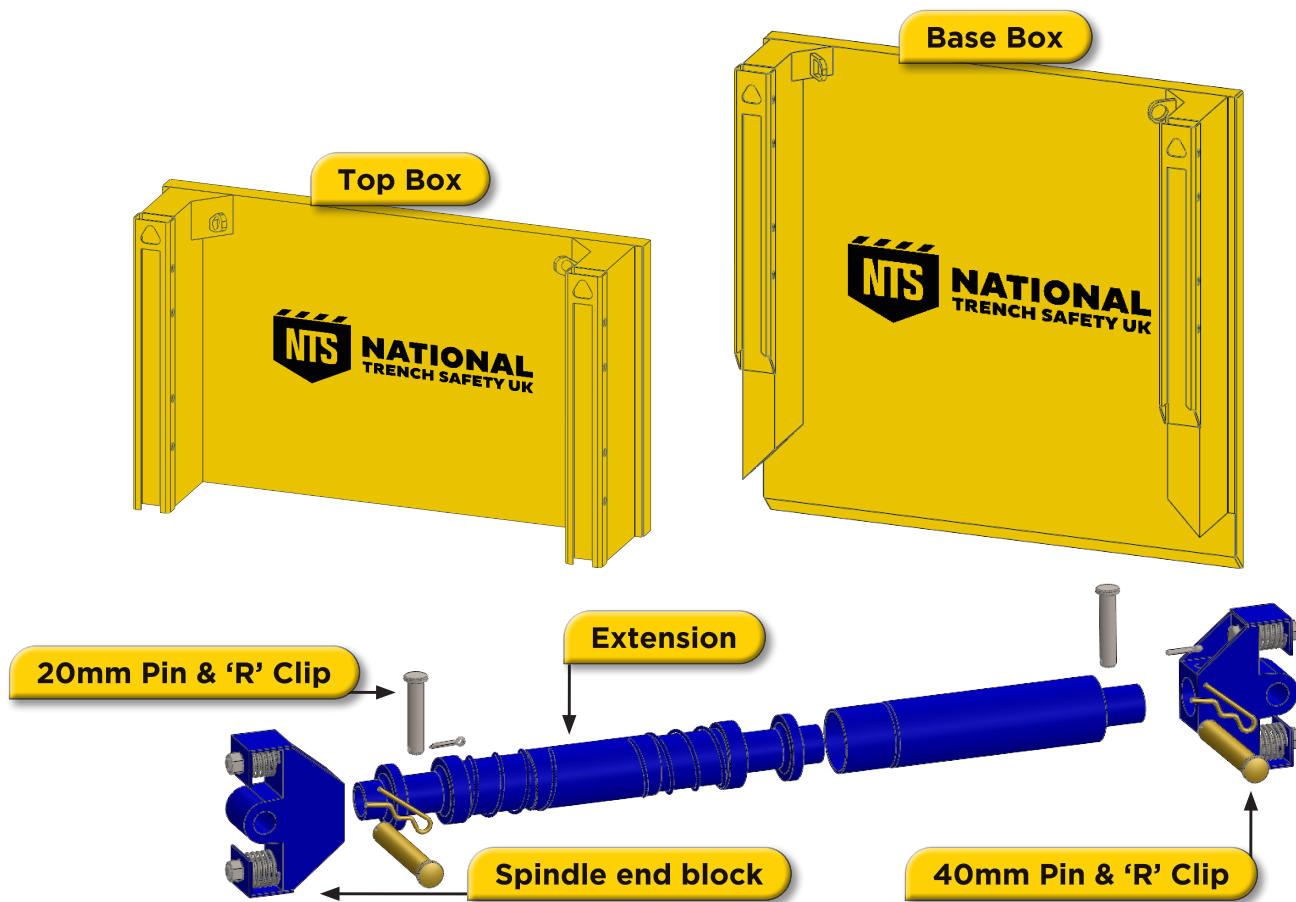

3.3 Spindle type 031/085 blue

allowed moment = 1,7 kNm

allowed tensile force = 218 kN

NUMBER OF EXTERNAL PIPES in 0,50m	WORKING WIDTH B _c		ALLOWED COMPRESSIVE FORCE (kN)	WEIGHT TOTAL (kg)
	MIN (m)	MAX (m)		
0	0,98	1,26	468	65,0
1	1,48	1,76	403	84,8
2	1,98	2,26	348	104,6
3	2,48	2,76	299	124,4
4	2,98	3,26	254	144,2
5	3,48	3,76	210	164,0
6	3,94	4,26	165	183,8

3.4 Accessories

NO.	DESCRIPTION	FOR USE WITH	DIMENSION (mm)	WEIGHT (kg)
1	Spindle end block	Spindle	95 X 290 x 193	13.1
2	Spindle	Shoring plates		40.2
3	Extension	Spindle	Dia - 120mm	See table above
4	Dowel and 'R' clip	All	70	7.6

4. Assembly Instructions

4.1. Manhole Box Series 600 Assembly

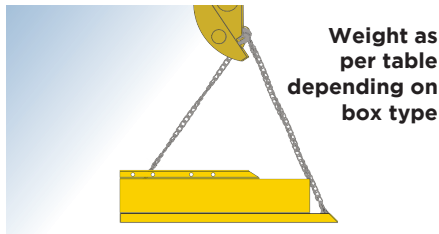

Weight as per table depending on box type

1 Lie first base panel flat on the ground with the wings pointing upwards.

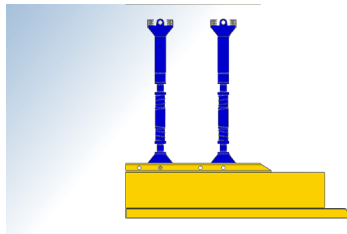

2 Assemble fixed length strut to the base panel using 40mm pins and 'R' clips.

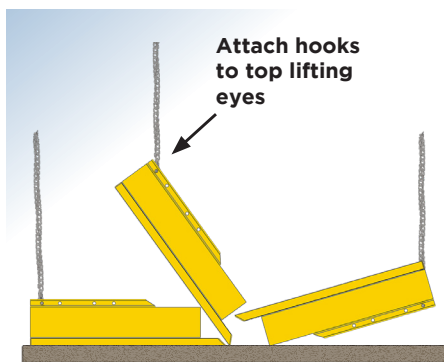
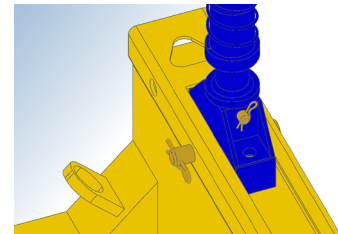

Attach hooks to top lifting eyes

3 Turn the other base panel over using 2 legs of the four leg sling. (Max. Weight: 510 kg)

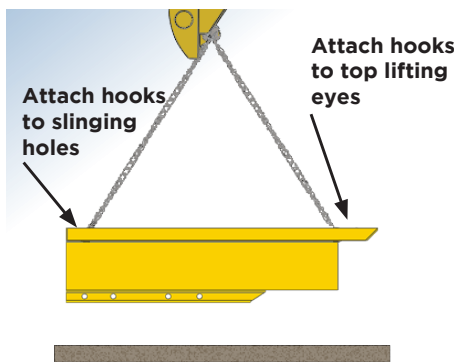

Attach hooks to slinging holes

Attach hooks to top lifting eyes

4 Re-sling this panel with the wings downwards (Use all 4 legs of the lifting chain)

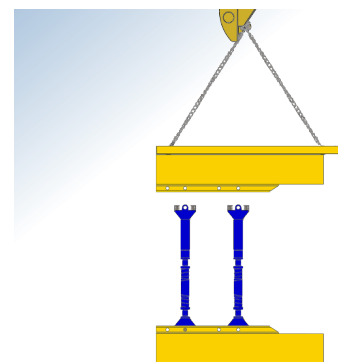

5 Complete assembly of the base box on it's side by pinning the struts to the upper panel. Remove the 4 leg sling.

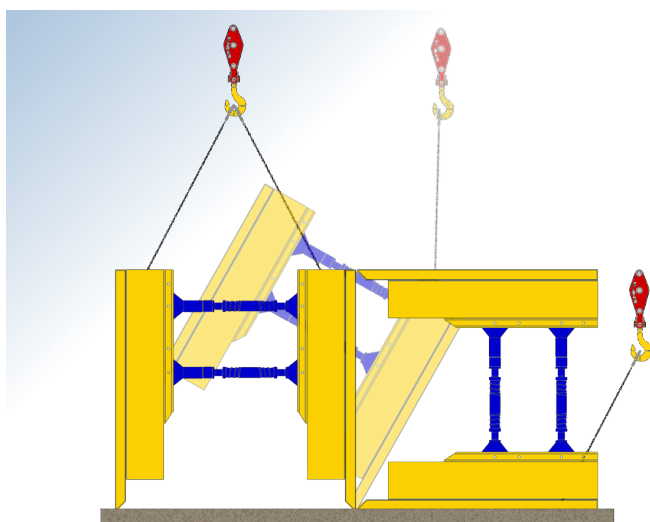

6 Attach 2 chains of the sling to UPPER lifting eyes of UPPERMOST panel and 2 chains of sling to UPPER lifting eyes on LOWER panel.

7 Stand the box on it's cutting edges with great care to avoid damaging the struts.

8 It is important to ensure the weights and radius are well within the lifting capacity of the machine to allow for impact and lurching effects as the box is turned upright.

9 The completed base box can now be installed.

5. Installation Instructions

5.1. Installation of Base Boxes

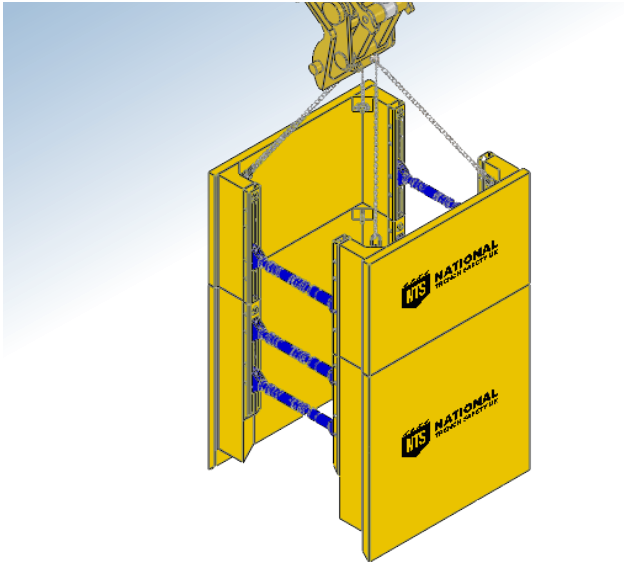

- 1 After standing upright check all pins and safety clips are in place. Lift the box using the four leg chain sling attached to the lifting points at the top of each panel.

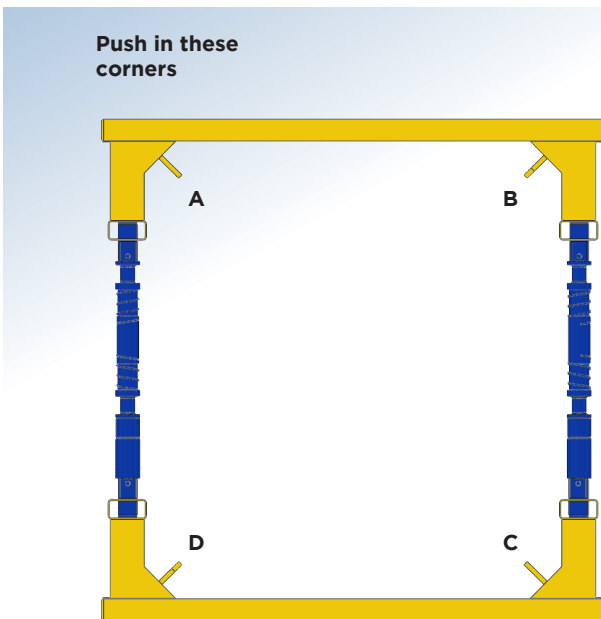

- 2 Dig the manhole approx. 600-1000mm deep to the correct width, and using the four leg sling place the box in the excavation.
- 3 By digging between the box panels and pushing down on the ends of the panels, the box can be installed to the correct depth.
- 4 Always dig below the panels before pushing down. Push only on the corners of each panel and never in the middle.
- 5 When pushing the box panels down, always push down in the sequence shown and never diagonally across corners. i.e. push A then B followed by C then D, and not A then C or B then D.

5.1. Installation of Base Boxes

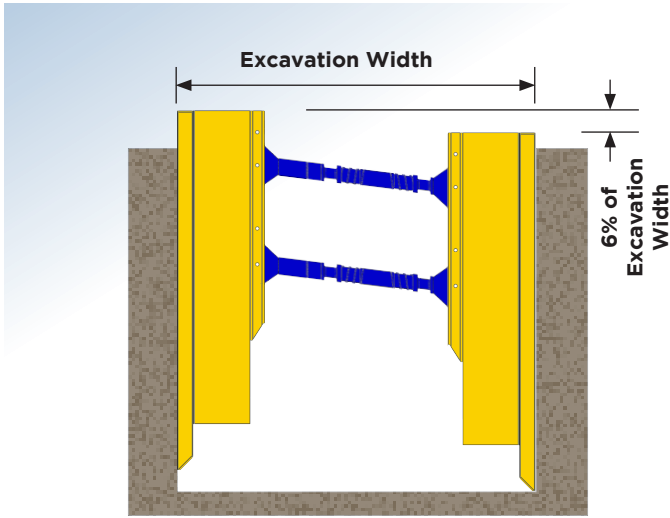

6 During the dig and push operation (2) restrict the advance of one panel over the other to 6% of the box width.

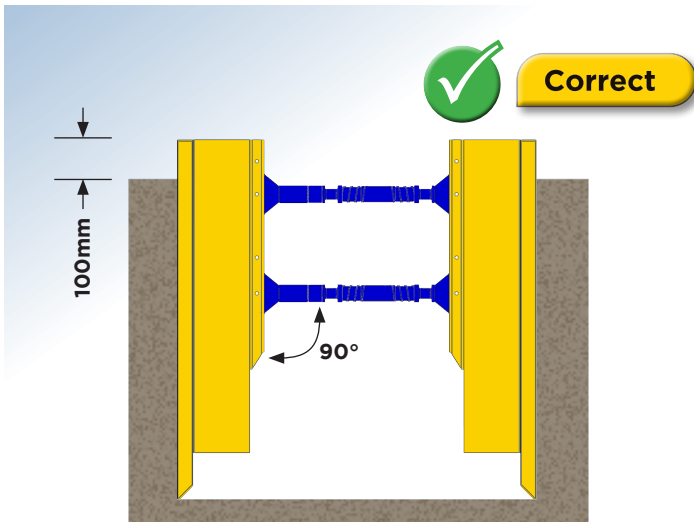

7 When the required excavation level is reached and the box sunk to full depth, ensure that the struts are horizontal and at right angles to the panels before entering the excavation.

DO NOT use any unsupported part of the excavation for access. Leave the top of the box 100mm above the surrounding ground level.

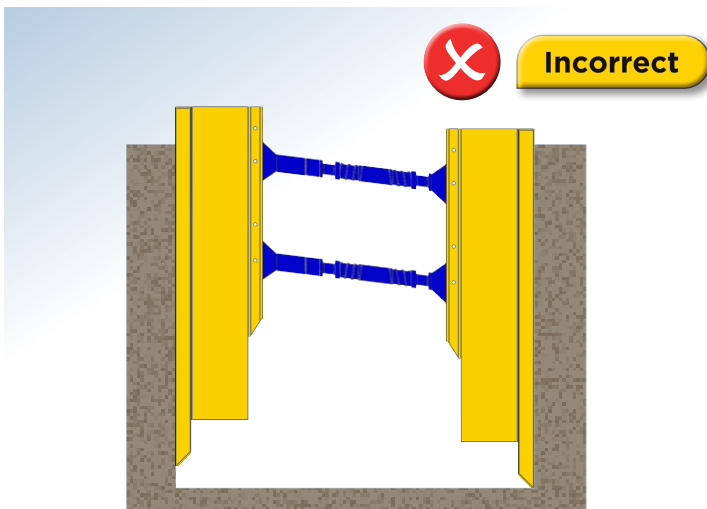

5.2. Installation of Top Boxes

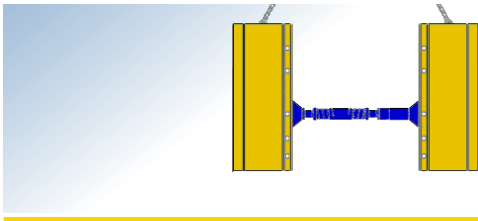

1 Dig and Push base box to within say 300mm of top of base box.

2 Pre-assemble the top box to the trench width and suspended by the four lifting rings on the posts.

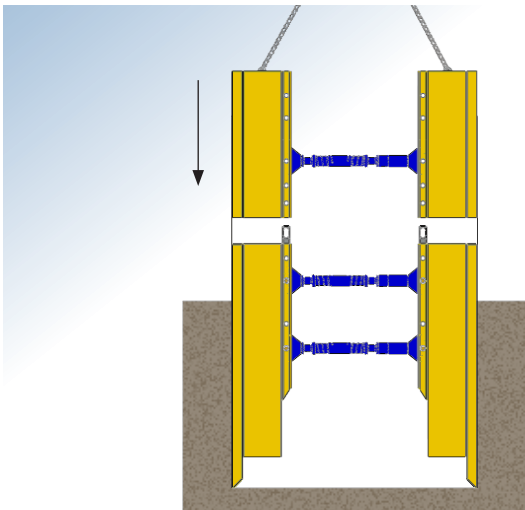

3 Align the top box and lower into position over the Base Box.

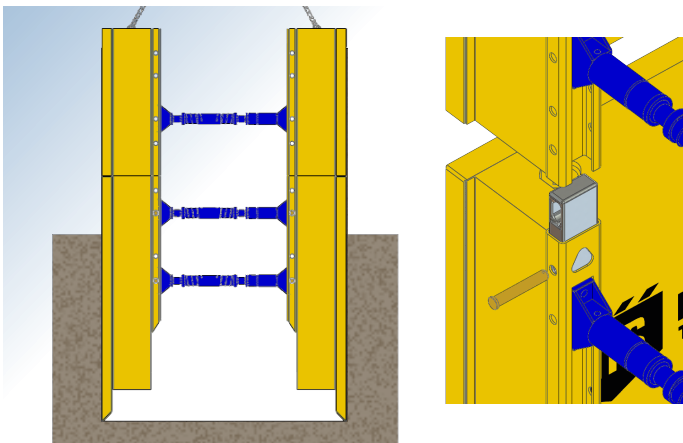

4 Attach the top box to the base box using box connectors and $\text{Ø } 20 \times 150 \text{ mm}$ pins & 'R' clips.

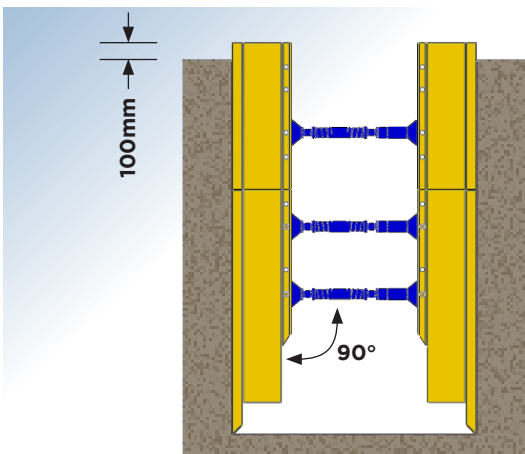

5 Continue the dig and push operation until the required excavation level is reached. Ensure all the struts are horizontal and at right angles to the panels before entering the excavation.

DO NOT use any unsupported part of the excavation for access. Leave the extension 100mm minimum above the surrounding ground level.

5.3. Isometric Drawing

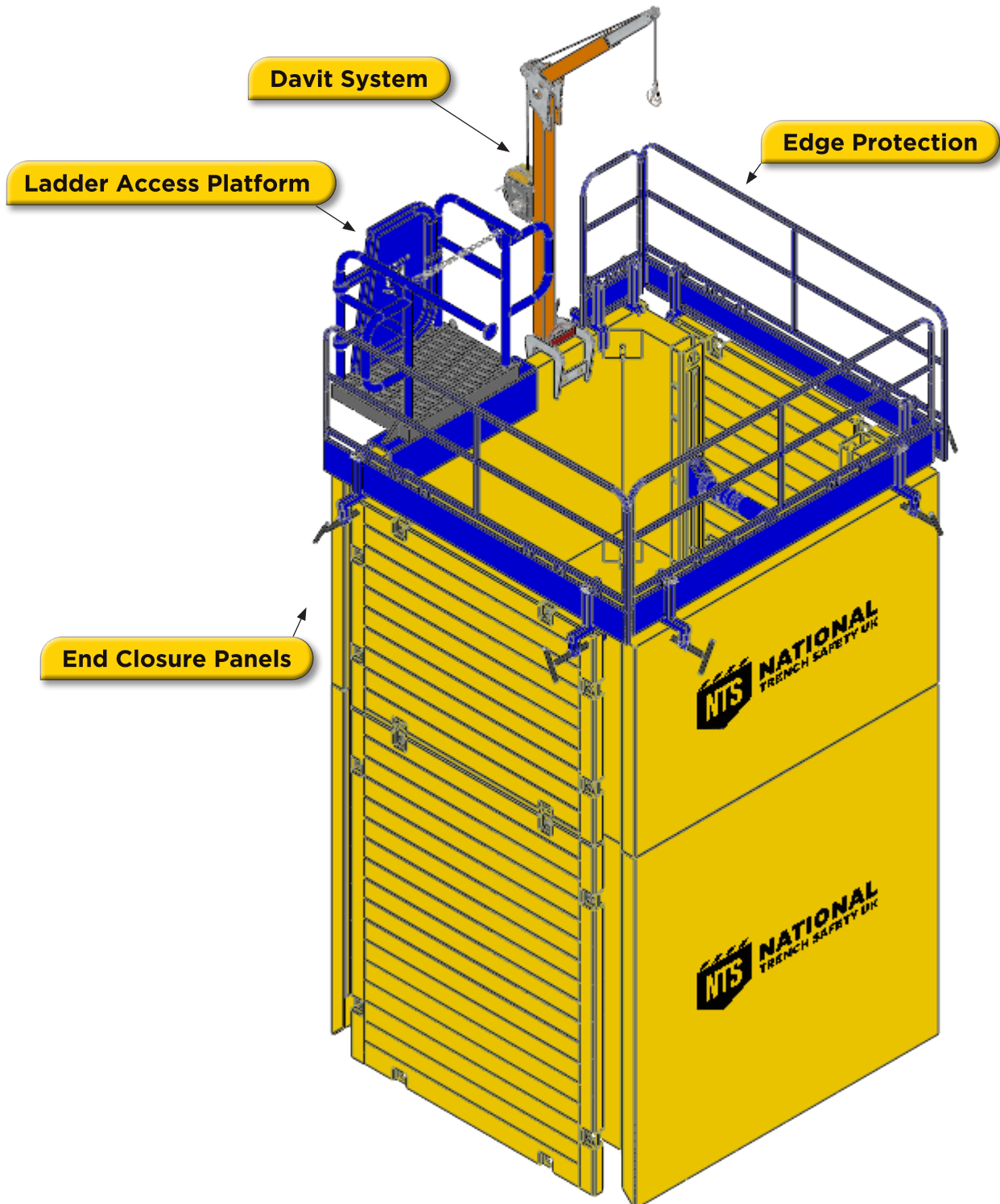

NOTE: DON'T FORGET YOU WILL NEED A LADDER, LADDER ACCESS PLATFORM, DAVIT SYSTEM AND EDGE PROTECTION TO COMPLETE YOUR INSTALLATION.

5.4. End Closure Panels

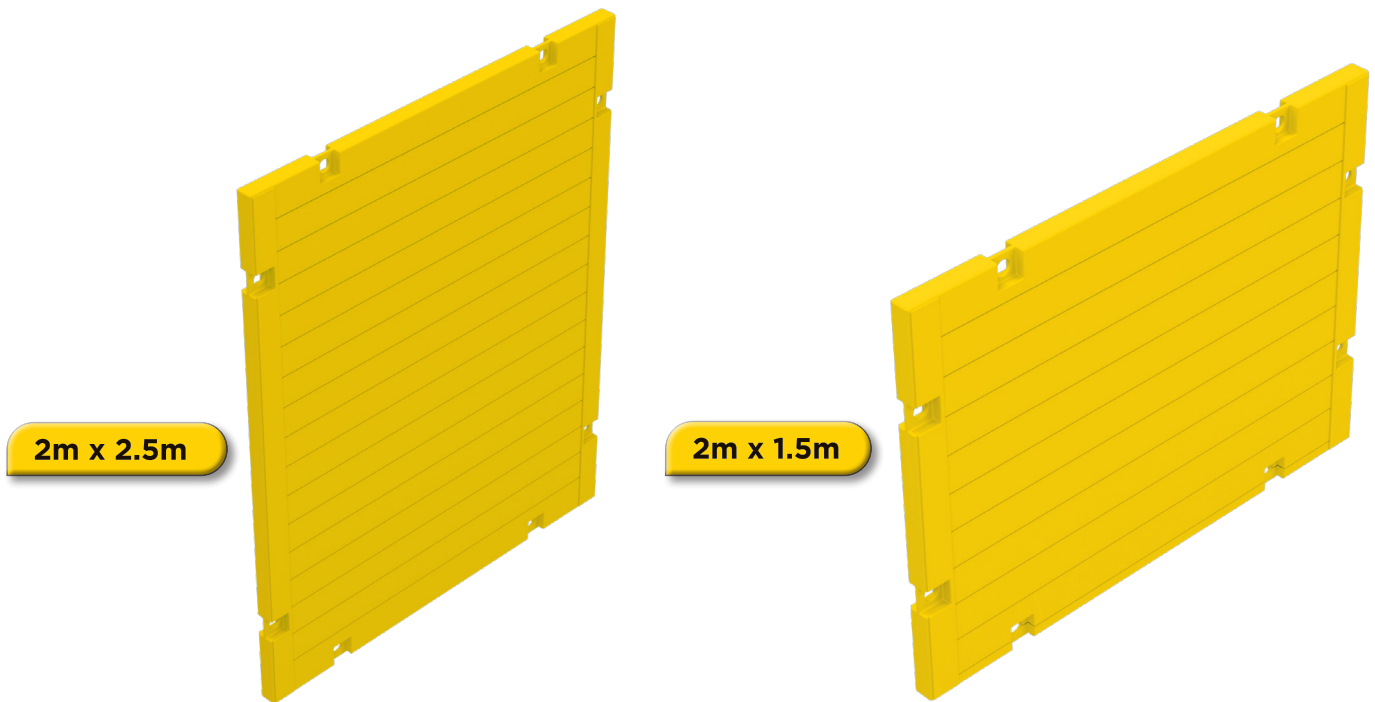

PRODUCT	ALLOWABLE PLATE BOWING MOVEMENT (KN/M2)	MAXIMUM PRESSURE (KN/M2)	WEIGHT (KG)
3.5m x 2.0m		34	775kg
3.5m x 1.0m			440kg
3.0m x 2.0m		34	525kg
3.0m x 1.0m			300kg
2.5m x 2.0m	29.5	40	455kg
2.5m x 1.0m			265kg
1.5m x 2.0m	29.5	40	350kg
1.5m x 1.0m			185kg

5.5. Before Entering the Trench

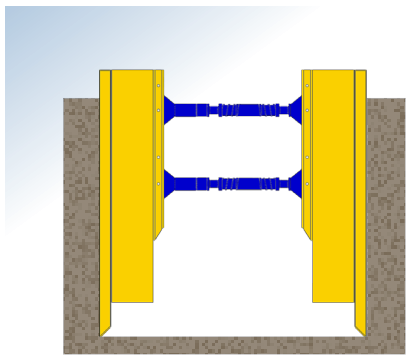

Correct

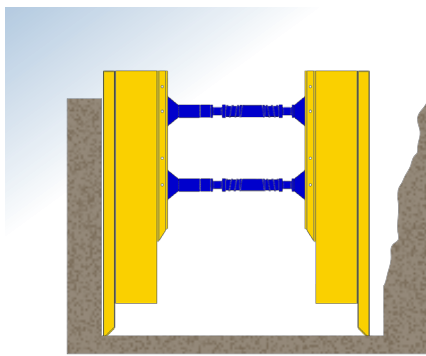

Incorrect

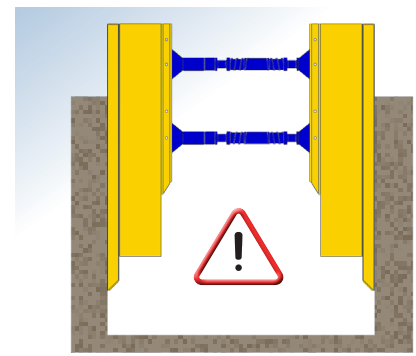

1 Ensure that there are **NO** voids between the box panel and the trench sides as this may cause the box to move sideways.

2 **DO NOT** leave the base of the box 'flying' above the trench level.

5.6. Entering the Supported Trench

- 1** Use a ladder to enter the working space between the struts of the Manhole Box Series 600.
- **DO NOT** climb up or down the struts.
 - **DO NOT** use any unsupported part of the trench for access.
 - **DO NOT** move the box when personnel are inside it.
 - **Wear a safety helmet to minimise the risk of injury.**
 - **Ensure that the excavator operator is aware of your intentions.**

NOTE: DON'T FORGET you will need a ladder, ladder access platform and trench protection to complete your installation.

5.7. Extraction of Manhole Box 600's

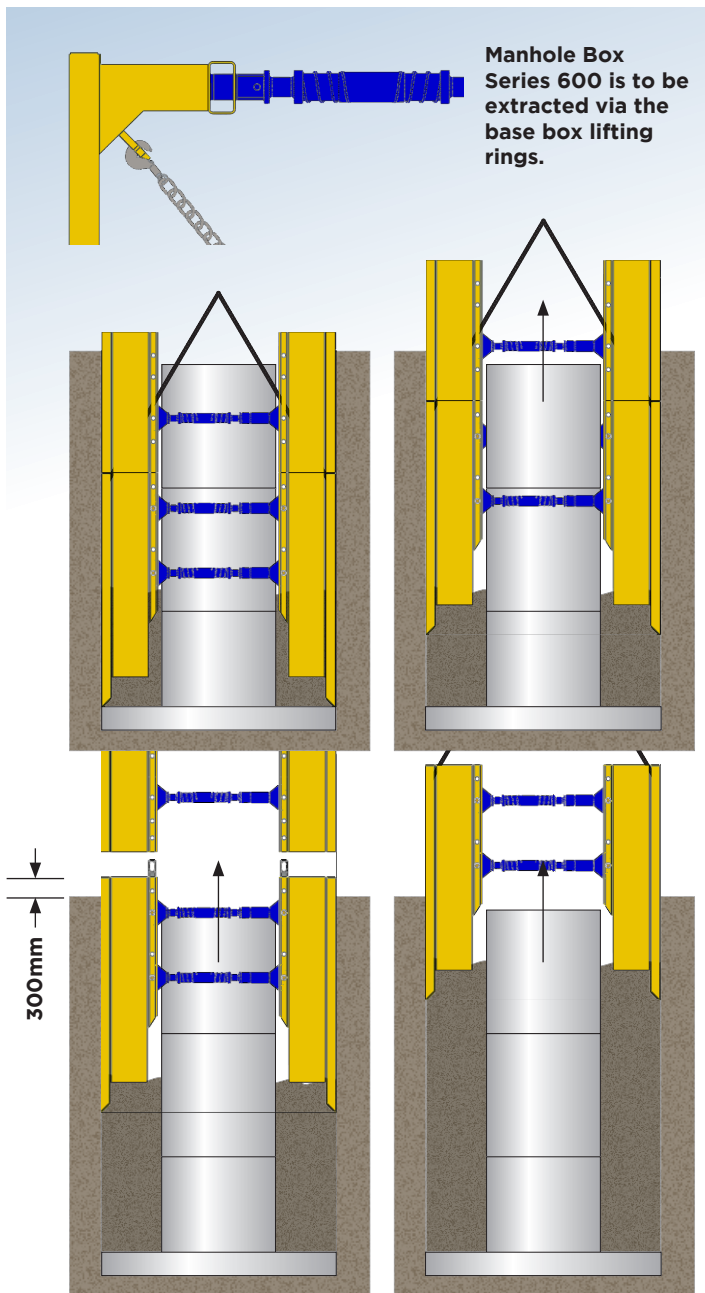

Due to the consolidation of the ground against the modules, it is usually more difficult to extract Manhole Box 600 boxes than to insert them. Methods for extracting are as follows, remembering that all lifting must be done at the points provided.

- 1** After initial backfilling and compaction, lift the base box complete with extension box if fitted from the manhole using the 4 leg chain attached to all 4 upper lifting points of the two BASE panels. Continue backfilling as removal of the box proceeds.
- 2** Alternatively, if the extension box is to be removed from the base box, lift as per (1) until the top of the base box is approx. 300mm above ground level.
- 3** Remove the 2 no. corner pins securing one of the extension panels to the base and the 2 no. pins securing one of the extension panels to the struts.
- 4** Lift the panel from the base. Remove the two no. corner pins securing the other extension panel to the base and lift this panel complete with struts off the base.
- 5** Remove the struts from the extension panel and stack panels and struts as per section 8. Continue backfilling as removal of the base proceeds.

DO NOT remove the extension panels before the top of the base is above ground level.

NOTE : No personnel should be inside the Manhole Box 600 whilst extraction is in progress.

5.8. Precautions During Use and Maintenance

- 1** Regularly check all pins are in place and 'R' clips are fitted.
- 2** Avoid laterally loading the struts - either by hanging or propping from them or by accidentally striking them with site plant. Damaged struts should not be used.

CLIENTS SHOULD ENSURE THAT ON REMOVAL, THE EQUIPMENT IS RETURNED CLEAN AND ASSEMBLED AS SUPPLIED.